

DOCUBIND TL300
B I N D I N G S Y S T E M

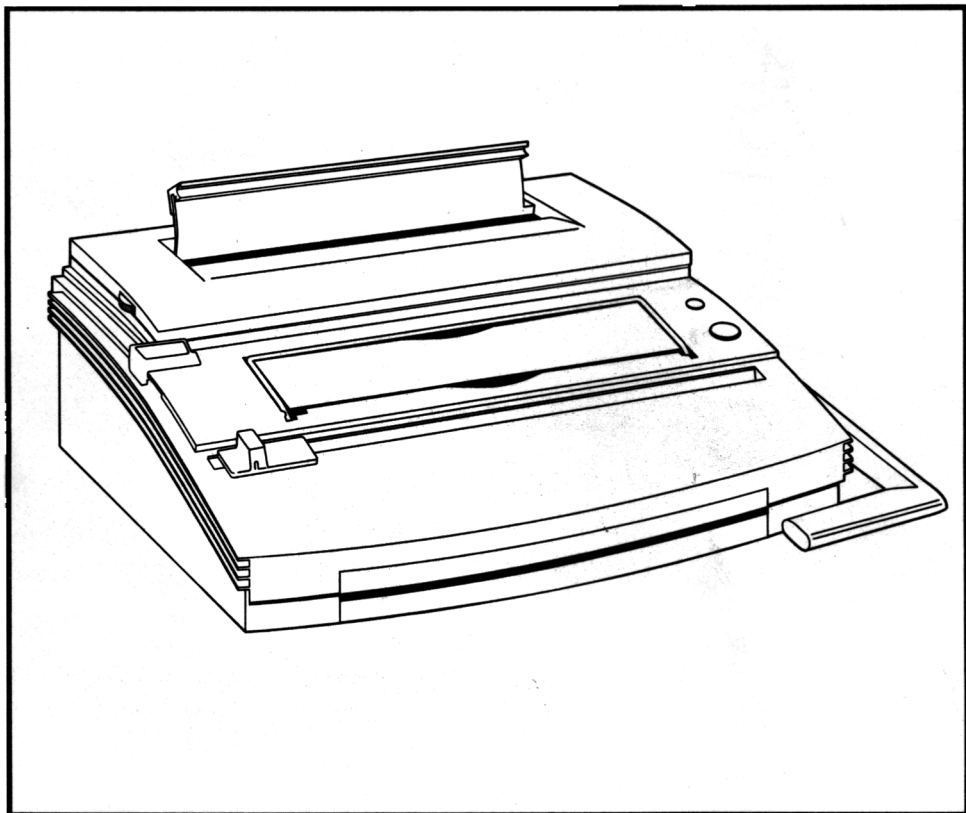

**Operating
Instructions**

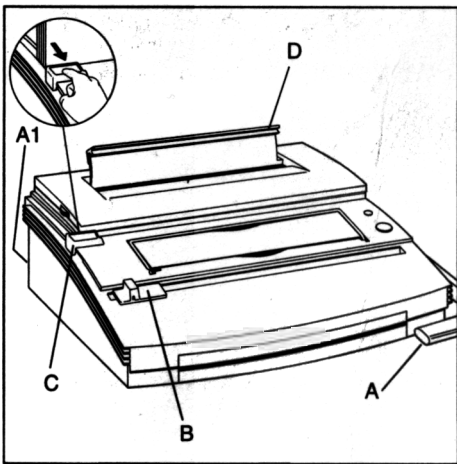

Figure 1

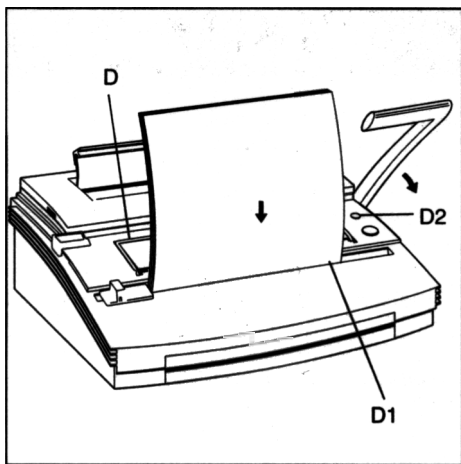

Figure 2

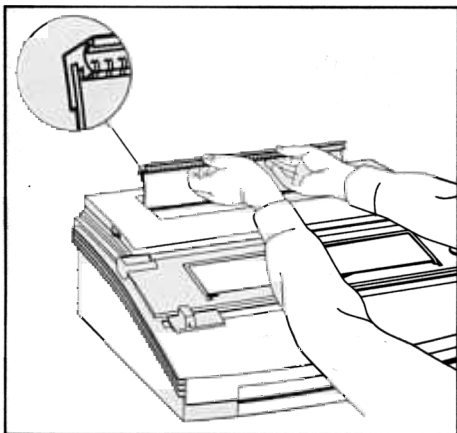

Figure 3

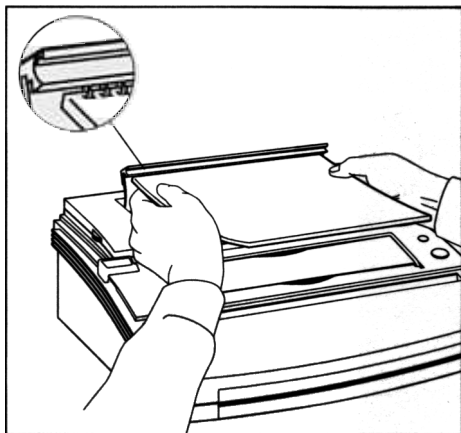

Figure 4

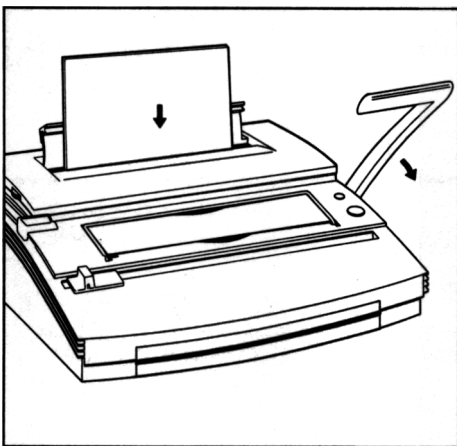

Figure 5

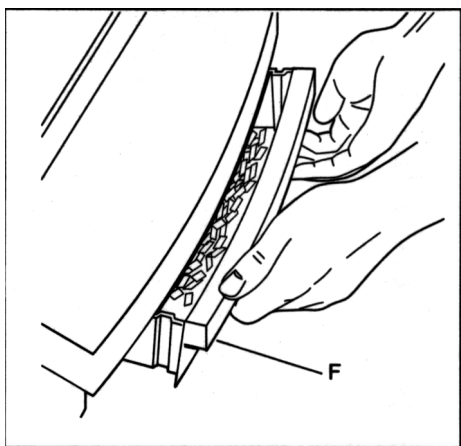

Figure 6

Thank you for purchasing the GBC DocuBind TL300. This system features our new exclusive wire holder design that enables you to assemble your document as you punch, making it easier to load paper onto the binding comb than previous systems! The DocuBind TL300 advanced punching technology also makes it easier to punch more paper at once while providing greater reliability.

A. GETTING STARTED

1. Push the handle (A) onto the shaft located on the right side of the machine (see figure 1). Align the flat spot of the handle with the flat of the shaft and secure it with the allen wrench provided.
2. Insert U shaped wire support bracket into holes on top rear of machine.
3. Firmly push the female end of the power cord into the power cord receptacle (A1) located on the back of the machine.

CAUTION: Make sure this step is complete prior to plugging the male end of the power cord into a power receptacle.

4. Plug the male end of the power cord into an appropriate power receptacle.

B. DETERMINE SHEET WIDTH



1. Set Edge Guide (B) to paper size you wish to bind (11", 8-1/2" letter size, 11-1/4" oversized cover, A4 ring, A5, Japan A4) (see figure 1). When using oversized covers, set the Edge Guide on Covers, punch all of the covers for your job and set aside. Move the Edge Guide back to the 11" setting to punch your contents then bind.

C. DETERMINE WIRE SIZE

1. Slide the Binder Sizer open (C) (see figure 1).
2. Place document including covers behind Binder Sizer.
3. Release the Binder Sizer and select the wire binding element that corresponds with the size shown by guide. For best results, always use GBC brand covers with GBC color-coordinated wire.

D. PUNCHING PAPER (see figure 2)

1. Lift the Paper Support (D) into place (optional).
2. Align sheets or covers and insert edge to be bound into punch throat (D1).
3. Jog the sheets until they are flush against the edge guide and the bottom of the punch throat. Allow the paper to rest against the Paper Support, or, you may prefer to hold the sheets in place with one hand.

4. To punch, press the PUNCH  button (D2). The DocuBind TL300 punches up to 12 sheets of 20 lb./80 gram paper at once. Punch only TWO clear covers at a time to prevent jams and excessive wear.
5. If punch jams, depress the RESET  button (D3). Then press the PUNCH  button (D2) again and remove paper or covers from punch throat (it may be necessary to punch several times in order to remove the paper). Repeat steps 1 to 4 with slightly less paper to avoid punch jams on additional lifts.

E. BINDING

1. Using the dial on the left side adjust the Wire Crimper to correspond with the wire element size to be used.
2. Place the large loops of the wire element into the Wire Holder as shown in figure 3. Be sure it is firmly secured with the small loops facing toward you.
3. Place your punched pages face downward onto the small loops of the wire element. Then place your front and back covers face-to-face against each other. Place the covers onto the wire element with the back cover first and the inside of the front cover facing upward. This step ensures that after crimping the seam of the wire element will be hidden between the back cover and last page (figure 4).
4. Hold the wire element firmly at each end of the book and remove it from the Wire Holder by sliding it to the left or lifting it off. While firmly holding the wire element at each end place the book with the open end of the wire face down into the Wire Crimper. You can release the book so it rests against the support rack or continue to hold it with one hand (figure 5).
5. To crimp the wire together pull the handle down toward you completely until it goes no further. Remove the book and flip the front cover around to the front. Your presentation is now complete.

F. EMPTY CHIP DRAWER

1. Empty Chip Drawer (F) after repeated use. Pull drawer gently toward you to open. When putting back in, the drawer will snap into place (see figure 6).

G. SERVICE

Should your DocuBind require service contact:

Quartet, a GBC Company
5700 Old Orchard Road
Skokie, IL 60077 USA
1-800-541-0094
<http://www.quartetgbc.com>

SPECIFICATIONS

Dimensions:	18" (W) x 8 1/2" (H) x 16" (D) 457mm x 216mm x 406mm	Punch Capacity:	12 sheets of 20 lb. paper 12 sheets of 80gm ² paper
Weight:	35 lbs. (15.5 kg.)	Bind Capacity:	125 sheets or 9/16" (14mm)
Electrical Power:	115V AC, 60Hz, 4.3 amps, 130 watts or 230V AC, 50Hz, 1.3 amps	Maximum Sheet Width:	11.7" (297mm A4)
		Dis-engagable Punch Pins:	1 (A5 paper) within wire storage bin

SAFETY MESSAGES

Your safety as well as the safety of others is important to GBC. In this Operator Manual and on the product are important safety messages. Read these messages carefully.

 The safety alert symbol precedes each safety message in this Operator Manual. This symbol indicates a potential personal safety hazard that could hurt you or others, as well as cause product or property damage. The following warning is found on this unit:

This safety message means you could be seriously hurt or killed if you open the product and expose yourself to hazardous voltage.

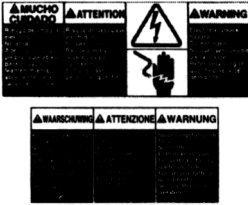

The following symbols appear on this product, and their meaning is as follows:

 **PUNCH**

 **RESET**

 **WARNING:** For your protection, do not connect the DocuBind TL300 to electrical power until you read these instructions completely. Keep these instructions in a convenient location for future reference. To guard against injury, the following basic safety precautions must be observed in the set-up and use of this product.

IMPORTANT SAFEGUARDS

GENERAL SAFEGUARDS

- Use the DocuBind TL300 only for its intended purpose of punching and binding paper and covers according to the indicated specifications.
- Do not place anything in the punch opening of the machine other than paper and cover stock.
- Place unit on a secure, stable work area to prevent the machine falling and possibly causing personal injury and damage to the unit.
- Follow all warnings and instructions marked on the product.
- Lift the machine from the bottom, not the cover.
- Do not lift the machine by the cover or paper holder wire.

ELECTRICAL SAFEGUARDS

The DocuBind TL300 must be connected to a supply voltage corresponding to the electrical rating of the machine as indicated in the serial/rating plate or in this manual.

 **CAUTION: THE POWER RECEPTACLE MUST BE LOCATED NEAR THE EQUIPMENT AND BE EASILY ACCESSIBLE.**

 **CAUTION: IN CASE OF EMERGENCY, USE THE POWER CORD AS A MAIN DISCONNECT DEVICE!**

- Unplug the DocuBind TL300 before moving it, or when it is not in use for an extended period of time.
- Do not operate with a damaged supply cord or plug, after it malfunctions, or after it has been damaged in any manner.
- Do not overload electrical outlets beyond their capacity as this can result in fire or electrical shock.
- Do not alter attachment plug. Plug is configured for the appropriate electrical supply.
- The unit is intended for indoor use only.
- Never push objects into this product through cabinet slots. Do not spill liquid of any kind on this product.
- Do not operate if the product has been exposed to rain or water.

SERVICE

Do not attempt to service or repair the DocuBind TL300 yourself. Unplug the unit and contact an authorized GBC service representative for exchange or repair.

CLEANING

 **CAUTION:** Unplug this product before cleaning.

Wipe exterior only with a damp cloth. Do not use detergents or solvents.

The following notes apply only to the units rated 230V 50Hz.

MAIN CORDSET SELECTION (FOR 230VAC MACHINES ONLY)

When choosing a detachable line cord for use with the DocuBind TL300, always observe the following:

The cordset consists of three components; the attachment plug, cordage and appliance inlet. Each of these components must meet European regulatory approvals for safety.

The following **minimum** electrical ratings for the specific cordset are published for safety purposes. **DO NOT USE CORDSETS THAT DO NOT MEET THE FOLLOWING MINIMUM ELECTRICAL REQUIREMENTS.**

PLUG: 3A, 250 volts, 50/60 Hz, Class 1,3 conductor, European safety agency approved.

CORDAGE: Type H05VV-F3G0.75, Harmonized (< HAR >). The "< >" symbols indicate cordage approved to appropriate European standard (NOTE: "HAR" may be substituted by the approval mark of the European safety agency which approved the cordage. An example would be "< VDE >").

APPLIANCE CONNECTOR: 3A, 250 volts, 50/60 Hz, European safety approved, Type IEC 320. Cordset shall not exceed 3 meters in length. Cordset with component electrical ratings greater than the minimum specified electrical ratings may be substituted.



QUARTET®

A GBC COMPANY
SKOKIE, IL 60077
<http://www.quartetgbc.com>